

**STRICTLY CONFIDENTIAL**

FOR PHILIPS SERVICE

DEALERS ONLY



COPYRIGHT 1937

# PHILIPS

## SERVICE MANUAL

### SUPERHETERODYNE ALL-WAVE MULTI-INDUCTANCE RECEIVER

For A.C. Mains,  
110/250 volts

## Type 748A

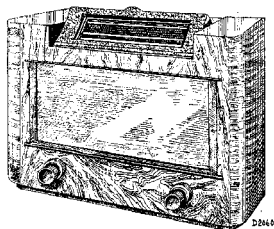

#### GENERAL REMARKS.

The receiver is designed for the following wave-lengths:—

- A. 16.5—51 metres (18.2—5.9 K.C. Short Wave).
- B. 198—595 metres (1,515—521 K.C. Medium Wave).
- C. 725—2,000 metres (414—150 K.C. Long Wave).

It is provided with delayed automatic volume control; variable tone filter; muting switch; a mains aerial; sockets for the fitting of a gramophone pick-up; sockets for fitting an extra loudspeaker of high impedance.

At the back of the instrument a mains socket is fitted to the removable back so that when the latter is removed from the receiver the instrument is completely free from voltage.

The large knob on the left-hand side of the cabinet controls the variable tone filter, while the smaller knob operates the volume control. The large knob on the right-hand side of the cabinet is the wavechange regulator, and mains switch, and the smaller knob is for tuning.

The receiver is designed for a mains frequency of 50—100 cycles, and also can be adjusted for the voltages:—110 v., 125 v., 145 v., 200 v., 220 v. and 245 v.

#### DESCRIPTION OF CIRCUITS.

In the first place the circuits are described with the instrument adjusted for the medium-wave range.

The aerial voltages which are received are inductively (S7) and capacitively (C28) coupled with S9. S9 forms together with C10 the trimmer C14, and the coupling condenser C30, the first tuned circuit of the capacitively coupled band pass filter, while the second tuned circuit consists of S11, C11, C15 and C30.

The voltage across C11 is fed via R32 to the fourth grid of L1. The function of this resistance is to prevent parasitic oscillation when short-waves are being received.

The tuned circuit of the oscillator comprising S14, C12, the parallel padding condenser C17 and the series padding condenser C33 is connected to the first grid of L1. The coil S16 is back coupled to S14 and connected to the second grid of L1. The cathode, together with the first and second grids of L1, should be regarded as an oscillating triode, the frequency of which is 128 K.C. higher than the frequency to which the H.F. circuits are tuned.

By means of the padding condensers the differences in tuning between the H.F. circuits and the oscillator circuits is maintained practically constant. The parallel padding condenser ensures that the lower

part of the tuning curve remains constant, while the series padding condenser controls the upper part of the system.

The frequency changer valve enables a mixing effect of the oscillator and signal frequencies so as to maintain the frequency difference of 428 K.C.

This frequency is passed from the anode circuit of L1 to the coil S20 and condenser C22 which are tuned to the I.F. frequency.

The intermediate frequency voltage across S20 is induced into the coil S21 which is tuned by C23. These two circuits constitute an inductively coupled band pass filter.

The intermediate frequency voltages are coupled by the valve L2 and passed to the second inductively coupled band pass filter to the first diode anode of the valve L3.

The secondary winding of the second I.F. band pass filter consists of the coils S23, S24. The first diode anode of the double diode triode valve L3 is connected to the tapping of this circuit in order to obtain a smaller amount of damping effect. The I.F. voltage across S24 is rectified, consequently forming a D.C. voltage with a super-imposed L.F., A.C. voltage. The current flows through this circuit via the first anode, cathode, R14, R15, S24.

The low frequency A.C. component voltage is passed to R15 (volume control) and coupled via the condenser C37 to the control grid of L3 and further amplified by the resistance capacity circuit formed by R21, C40, R16, R17. The output from this valve is passed to the loudspeaker output transformer S26, S27, the secondary of which is connected to the speech coil S28 of the permanent magnet loudspeaker. The condenser C41 is for tone compensation and suppresses the higher frequencies.

R26 prevents L4 from oscillating at a very high frequency and C42, R23 and R22 comprise the variable tone control. The second diode anode of L3 is, owing to the voltage difference across R9 and R18 and R13 negative to the cathode, so that a current is only set up when I.F. signals are received above a certain definite value.

The I.F. voltage is passed, via C36, to the second diode anode of L3, but when strong signals are received a larger current will flow in the circuit, second diode, anode, cathode, R18, R9, R13, which cause the voltage at the second anode to become more negative. This voltage is fed as an extra negative grid voltage to the fourth grid of L1 via R12, C35, R10 and C30, and therefore reduces the amplification. The amplification of L2 is also regulated by an extra negative grid voltage which is passed via S21 to the control grid of L2 and decoupled by the condenser C35.

The condensers C46 and C47 are fitted in the first H.F. section in order to suppress image frequencies. The coil S6 and condenser C13 in the aerial circuit forms an I.F. filter in order to prevent interfering signals at this frequency.

The various negative grid bias voltages to the valves are obtained owing to the voltage difference which occurs over the cathode resistances. These resistances are decoupled by various condensers in parallel with them.

L5 is a full wave rectifier, while C1, C2 and S5 form the smoothing filter.

C27 is controlled by the small left-hand knob, and when depressed places R16 to earth via the condenser and consequently provides a means of muting the receiver.

For both the long and the short-wave bands the I.F. section is the same as that for the medium-wave. When the long-wave band is in use the following coils, condensers and resistances are switched in.

**Aerial circuit.**—S7 and S8.

**H.F. circuit.**—C28, S9, S10, C10, C14, C29, C30, S11, S12, C11 and C15.

**Oscillator.**—Grid circuit, S14, S15, C12, C17, C18, C32 and C33. Anode circuit S16, S17.

When the receiver is adjusted for short-wave reception the following component parts are switched in:—**Grid circuit of L1.**—S13, C11 and C31.

**Oscillator.**—Grid circuit S19, C12, C50, C34 grid condenser, R11 grid leak resistance. Anode circuit S18.

When the muting switch is pressed in with the knob on the left-hand side of the cabinet, C27 is connected in circuit. When the receiver is being operated for gramophone pick-up reproduction the aerial connection is open-circuited, the grid circuit of L1 is short-circuited, the voltage for the anode of the oscillator is open-circuited and the negative grid voltage is increased by removing the short-circuit on R31.

**NOTE.**—The short-wave side of the receiver has its oscillator frequency 128 K.C.'s lower than the frequency to which the H.F. circuits are tuned. When a gramophone pick-up is being used the receiver is connected via C35 and S21 with the control grid of L2. The screened grid of L2 then functions as an anode, R24 being a coupling resistance and C44 the coupling condenser.

The voltages are amplified via R15, etc., and passed to the valve L4 in the normal manner.

When the receiver is adjusted to the short-wave range C49 is switched in series with C37 in order to obtain more satisfactory speech reproduction.

## TRIMMING THE RECEIVER.

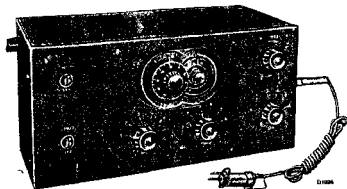

Fig. 1.

The receiver is equipped with trimming condensers so that any slight variation that may arise in the wiring of the circuit causing a capacity difference may be satisfactorily adjusted. If this is not done the amplification and selectivity will be considerably reduced owing to the tuning circuits not being exactly "in step."

In the first place the I.F. circuits are trimmed as this part of the circuit is utilised again for further balancing of the instrument.

When the primary winding of an I.F. transformer is trimmed the secondary must be damped, and again if the secondary is trimmed the primary must be damped. These damping resistances, etc., are necessary where tightly coupled circuits are involved in order to avoid two peaks in the resonance curve, and consequently they enable satisfactory trimming to be performed.

Where the various connecting points are difficult to reach, the damping resistance can be fitted to the plate or grid contacts, but in such cases a condenser of  $0.1 \mu\text{F}$  must be placed in series with the resistance so as to obviate short-circuiting of the D.C. voltages. The method of passing a signal to the control grid is shown in Fig. 2.

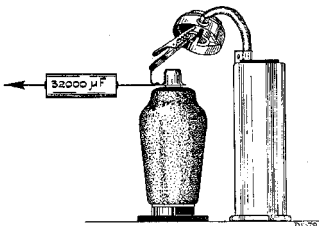

Fig. 2.

The grid cap must be connected to the grid and a signal passed via a condenser of  $32,000 \mu\text{F}$ . The volume control should be turned to maximum but if it is found that the signal is too loud then it will be necessary to reduce the attenuator of the service oscillator.

With regard to the trimming of H.F. and oscillator

circuits the following points should be noted:—The oscillator circuit is tuned to a frequency which is 128 K.C. higher than the frequency to which the H.F. circuits are tuned.

Commence by placing the condenser at a predetermined fixed position, namely  $15^\circ$  from the minimum, from which it can be adjusted by the aid of the template (see Fig. 3). When this has been done and the appropriate signal passed to the receiver the trimmers of the H.F. circuits and the parallel trimming condenser of the oscillator circuit can be adjusted.

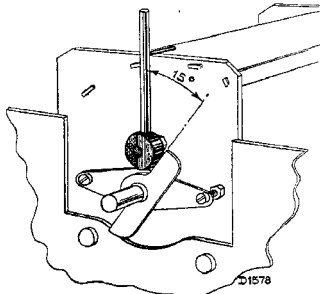

Fig. 3.

**NOTE.**—Before altering the trimmers it is necessary to soften the wax with a warm soldering iron. It is important that the trimming condensers should be handled very carefully, otherwise it is possible that the connecting wires soldered to the heads of the adjusting screws may become loose.

The receiver must be trimmed with the Frequency Changing Valve which is to be employed in the receiver. THE FOLLOWING INSTRUMENTS AND TOOLS WILL BE REQUIRED FOR TRIMMING.

1. A Service Oscillator similar to Philips Type GM.2880. (See Fig. 1.)
2. An output indicator similar to that which is fitted to the Philips Universal Measuring Test-board, or the special Adaptation Box GM.2295 which can be used between the receiver to be trimmed and a moving coil instrument.
3. A  $15^\circ$  template (Code No. 09.991.470). (See Fig. 3.)
4. An auxiliary receiver or an aperiodic amplifier similar to the Type GM.2404.
5. An insulated trimming screwdriver, Code No. 09.991.501. (See Fig. 4.)



Fig. 4.

6. A rectifying valve. Type 1823.

## C 2

It will be found that on the underside of the receiver a fibre subsidiary base plate is fitted. Therefore it is not necessary to remove the chassis from the cabinet when trimming the receiver.

The following instructions are for trimming the complete receiver.

### TRIMMING THE I.F. AND OSCILLATOR CIRCUITS.

The position of the trimmers are shown at Fig. 5

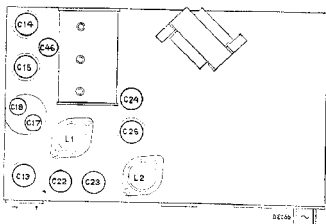

Fig. 5.

Switch the receiver to long-wave position. Place tuning condenser to maximum.

Apply a modulated signal of 128 K.C. via a condenser of  $0.03 \mu\text{F}$  on the fourth grid of L1; turn C13 condenser almost completely in. Damp C24 with a resistance of 25,000 Ohms, trim C25 to maximum output; remove the damping resistance. Damp C23 with a resistance of 10,000 Ohms and a condenser of  $0.1 \mu\text{F}$  in series and trim C22 to maximum output; remove the damping resistance, etc. Damp C25 with a 25,000 Ohms resistance, trim C24 to maximum output; remove the damping resistance. Damp C22 with a 10,000 Ohms resistance and an  $0.1 \mu\text{F}$  condenser in series, and trim C23 to maximum output; remove the damping resistance.

### TRIMMING THE H.F. AND OSCILLATOR CIRCUITS.

Switch the receiver to medium-wave. Place  $15^\circ$  template to the condenser (see Fig. 3) and adjust the variable condenser. Pass a signal of 1,442 K.C. (208 metres) to the aerial socket via the artificial aerial. Trim C17 and then C14 and C15 until maximum output is reached. Re-check to make sure all trimming condensers are in their correct position.

Switch the receiver to long-wave, place the variable condenser in position against the  $15^\circ$  template. Trim C18 until maximum output is obtained.

**NOTE.**—When trimming the oscillator section it is possible for heavy oscillation to occur. Further trimming should be effected until the correct position is obtained.

### I.F. AERIAL FILTER.

Place a strong modulated signal of 128 K.C. to the aerial socket. Switch the receiver to the long-wave range, place the variable condenser to maximum and trim C13 to minimum output.

### IMAGE FREQUENCY FILTER.

1. Place a modulated signal of 744 K.C. (403 metres) to the aerial socket. Tune the receiver.
2. Place a **strong** modulated signal of 1,000 K.C. (300 metres) to the aerial socket. Trim C46 for minimum output. After trimming cover all trimmers with wax.

### CALIBRATION.

When it is found necessary to repair the receiver so that the calibration has been effected the following method should be adopted for calibrating the instrument. The wavelength of 208 metres should be used as this is the best part of the scale at which accurate calibration can be obtained.

1. Switch the receiver to medium-wave.
2. Place a signal of 144 K.C. (208 metres), tune the receiver. Adjust the indicating pointer to the part of the scale marked 208 metres. Apply a signal of 857 K.C. (370 metres) and check to make sure that it is correct in position. Finally apply a signal of 550.4 K.C. (545 metres) and again tune the receiver.

The method of adjusting the bracket of the drum disc is shown in the table below.

350 metres	545 metres	208 metres
Good ...	Too high ...	↑ or ↙
Good ...	Too low ...	↘
Too high ...	Too high ...	←
Too high ...	Good ...	↓
Too high ...	Too low ...	↓
Too low ...	Too high ...	↑
Too low ...	Good ...	↑
Too low ...	Too low ...	→

Each time the bracket is displaced it will be necessary to retune again to 208 metres and correct the indicator.

## HOW TO TRACE FAULTS.

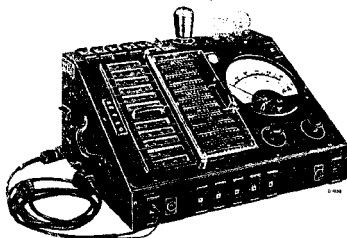

Fig. 6.

## GENERAL REMARKS.

Fault finding will be considerably facilitated by the use of efficient testing apparatus. Attention is drawn to the Philips Universal Measuring Test-board (Fig. 6) which enables both A.C. and D.C. voltages and currents, capacities and resistances to be measured over a large number of ranges.

Furthermore, particulars are given of the "point to point" method of testing a receiver, and it will be found that this method considerably assists in finding any defect that may have occurred in the instrument.

Particulars and prices of the Universal Test-board can be obtained from the Service Department, Mitcham Junction, Surrey.

In general it may be said that the majority of faults are due to short circuits in the bare wiring or to open or short circuits in one of the component parts. These are indicated as R... or C... as the case may be. The method of test should be as follows:—

- I. Carefully check all contacts connected to the removable back, mains switch, loudspeaker switch and the filaments of the valves. If the valves burn normally, this indicates that the safety contacts, mains switch and filaments of the valves are in order (subject to the possibility that the filaments of one of the valves may be short-circuited). Check the receiver with another set of valves that are known to be satisfactory and also try another loudspeaker.
- II. If there is still no output test to see if gramophone reproduction is possible.
- III. Check the voltage across C2 by measuring between the primary of the loudspeaker transformer and chassis. If this value is abnormal then any of the following defects may possibly have occurred.
  1. A fault in the mains switch or in the voltage adjusting disc. (Measure voltage and current of the primary of the mains transformer.)
  2. A fault in the mains transformer. (Measure the voltage of the secondary side of the mains transformer.)
  3. A defect in the rectifying valve.
  4. C1, C2, C5, C44 short-circuited.
  5. S5 open-circuited.
  6. An open circuit or short circuit in one of the heater wires.
  7. A short circuit in one of the I.F. transformers.

8. A short circuit between the primary and secondary windings of the loudspeaker output transformer.

9. A faulty contact in one of the valve holders.

## IV. Voltage across C2 normal but no gramophone reproduction.

## A. L4 has abnormal current and voltages.

1. No anode current; S26, S30, R27 open-circuited.
2. Anode current too high; C40 short-circuited.
3. R16, R17, R26 open-circuited.

## B. L3 has abnormal current and voltages.

1. No anode current; R21, R18, R9 open-circuited, C39 short-circuited.
2. Anode current too high; C4 short-circuited.
3. R19 open-circuited.

## C. L3 and L4 have normal current and voltages but no radio or gramophone reproduction.

1. Short circuit in one of the screened connections; for instance the control grid of L3.
2. Short circuit in the loudspeaker transformer.
3. C40, R15, C37 open-circuited.

## V. Gramophone but no radio reception.

## A. L2 has abnormal current and voltages.

1. No anode current; S22, R5 open-circuited, C5 short-circuited.
2. Anode current too high; C9 short-circuited.
3. R1, R12, R25, S21 open-circuited.

## B. L1 has abnormal current and voltages.

1. No anode current; S20, R4 open-circuited.
2. Anode current too high; C8 short-circuited.
3. Anode current low; R1 open-circuited. R31 not being short circuited by switch. Switch No. 1 bad contact.
4. R11, R32, S16, S17, S18 open-circuited.

## C. L1 and L2 has normal current and voltages, but no wireless reception.

1. No reproduction of a modulated I.F. signal of 128 K.C. when it is connected to the control grid of L2; grid cap not connected. S22, S23, S24, C24, C25, C38 short-circuited. R14 open-circuited.
2. No reproduction of modulated I.F. signal of 128 K.C. transmitted through control grid of L1; grid cap not connected but connected to the control grid of L2. S20, S21, C22, C23 short-circuited.
3. No reproduction of a modulated H.F. signal to the fourth grid of L1, although reproduction of I.F. signal transmitted to the same part of the circuit. One of the coils or condensers in the oscillator section of L1 is either open or short-circuited, C12, C18, C33, R11, etc.
4. No reception of a modulated H.F. signal connected to the aerial socket although reception is obtained at the fourth grid of L1; (grid cap not connected). Open circuit in one of the coils or condensers in the aerial circuit or fourth grid circuit of L1, for instance C10, C11, C29, C30, C8, C9, S9, S10, S11, S12, S6 short-circuited, weak on long-wave range.

## VI. Wireless reception and gramophone, but quality not satisfactory.

## A. Automatic volume control not functioning.

1. R13, R12, R10, C36 open-circuited.
2. C29, C30, C35, C43 short-circuited.

E 2

**B. Receiver Oscillates.**

One of the decoupling condensers is open-circuited or the screening of the wiring open-circuited, for instance, C8, C9, C5.

**C. Receiver Hums.**

C1, C2 open-circuited, S5 short-circuited.

**D. Cabinet Resonances.**

This difficulty is probably due to a loose component such as valve caps, strips, or washers. When the vibrating part is found it should be securely fixed.

### FAULT-FINDING BY THE "POINT TO POINT" METHOD.

When the "point to point" method of testing is adopted in conjunction with a Philips Universal Test-board, Type 4256, a defect in the receiver may be quickly and systematically located.

In many cases it will be found that the chassis will not be required to be removed from the cabinet, and the following method is recommended:—

- I. The receiver is connected to the voltage to which it is adjusted, and is tested with its own valves on an outside aerial or service oscillator.
- II. Should the receiver not function, the valves should be replaced by another set of valves which are known to be in good working order, and also with another loudspeaker. If it is still found to be faulty it will be known that the valves and loudspeaker are in good order.
- III. A gramophone pick-up is connected to the receiver. If it is found that satisfactory reproduction can be obtained from this position then the chassis can be tested by working backwards, and subsequently placing an H.F. signal via a condenser of 0.1  $\mu$ F to the control grids of the various valves.
- IV. Should, however, no gramophone reproduction be possible or should the tests on the H.F. side of the receiver fail to give some result then the following tests should be made.

1. All the valves are removed from the receiver and a valve holder which has its anode and heater sockets connected is inserted in the valve holder of the rectifier. The receiver should not be connected to the mains.
2. A Philips Universal measuring Test-board (Type 4256) is then connected up and adjusted for resistance measuring (position 12). It is desirable that the positive pin of the test flex is sufficiently insulated and long enough so that the various parts of the chassis can be easily reached.
3. The various resistances between the points, indicated in the accompanying table, and chassis, are measured by touching each contact with the positive pin. The reading obtained should then be compared with the value shown on the table.  
P. indicates that measurements should be taken between the gramophone pick-up sockets and earth.  
21/22 indicates that a measurement should be taken between the points 21/22.

It is possible for discrepancies of 10 per cent. to occur without the component part being necessarily defective.

4. When the resistances have been measured the test-board should be adjusted for capacity measurement, and the values specified in the table are checked.
5. When it is desired to take a measurement from the valve holder of the rectifier then the short-circuiting of the latter is temporarily removed. All the circuits shown in the theoretical diagram are covered by these measurements and therefore identification of the faulty part can easily be obtained by reference to the diagram.

The various contacts to the valve holders are systematically numbered in the following way.

- 1 & 2 = heaters.
- 3 = control grid.
- 4 = metallizing contact.
- 5 = cathode.
- 6 = extra grid.
- 7 = a screening grid.
- 8 = anode.
- 9 = an extra grid (for instance when employed in the octode).

From the table of measurements it will be clearly seen that the numbers are grouped according to the value of the resistance or capacities, so that all grid circuits (13, 23, 33, etc.) are measured in position 9. On the other hand all heater and cathode connections which are of low resistance are measured at position 12. In some measurements it may be necessary to adjust the wavelength switch. When this is necessary it is indicated in the table as

$\frac{4X}{\text{Aerial}}$	$\frac{4X}{13}$
----------------------------	-----------------

When measurements are made on electrolytic condensers (resistance measurement) a deflection will, when the leak current is observed, be returned to a definite value. It may, however, be possible that the value is much too high owing to the condenser being defective, but it must be pointed out that if the receiver has not been in use for some considerable time, a similar type of reading will be obtained.

It is therefore desirable to check the electrolytic condensers carefully.

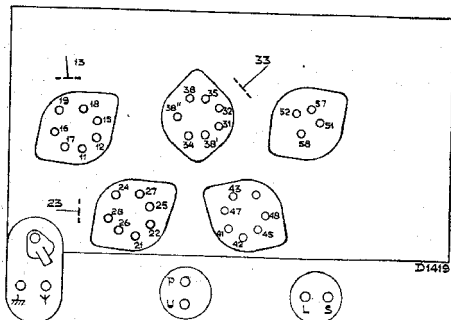

## RESISTANCES.

12	11	12	24	34	P	21 22	31 32	41 42										
	5	5	5	5	5	5	5	5										
11	4x 15	G	18	25	26	45	47	L	S	4X Aerial						57	58	
	290	470	375	285	430	215	355	430	350	S 500	M 60	L 200	G 500	220	215			
10	16	17	4x 19				27	28	35									
	150	180	S 180	M 180	L 180	G 5	285	490	490									
9	4 13				23	33	38	38'	38''	43	51	U	at Gram					
	S 500	M 105	L 105	G 500	80	105	375	230	210	155	500	230						

## CAPACITIES.

12	4x 13				38	33	38	38'	43									
	S 500	M 410	L 370	G 500	355	40	300	175	230									
11	17	23	27															
	270	295	365															
10	48																	
	250																	
9	35	45	52															
	460	460	485															

Volume control at maximum.



## REMOVING AND CHANGING OF PARTS.

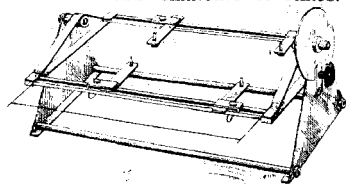

Fig. 7.

A chassis holder similar to that shown at Fig. 7 will considerably assist in making repairs and trimming.

The chassis is secured to the holder by four screws and can be rotated about its longitudinal axis. It can also be secured in any predetermined position with the aid of the brake-disc on the side, and also adapted for chassis of varying dimensions.

When repairing receivers the following points should be noted.

1. Always keep the wiring or screening plates in their original position.
2. Make sure that all the wires are kept clear of each other; not less than  $\frac{1}{8}$ ".
3. All washers, insulated material, etc., should be replaced in their original position.
4. Rivets can, if necessary, be replaced by screws and nuts.
5. Moving parts may be lubricated with a little pure vaseline unless otherwise stated.
6. If necessary place a slight tension on contacts.
7. Solder as quickly as possible so that the components are not overheated.
8. When soldering compound condensers, it should be done at least 1 cm. away from the compound in order to avoid overheating. All compound condensers should suspend free from all wiring.
9. All resistances should be fitted in such a way that they do not make any contact with other component parts.

The receiver is equipped with a special sub-base, and when the cabinet is placed upside down (on a piece of felt or similar material) it can easily be removed by taking away the screws and access can be had to the majority of parts inside the chassis. **The chassis should never be lifted by the coils.**

## REMOVING THE CHASSIS FROM THE CABINET.

1. Remove the knobs and bottom screws.
2. Unsolder the connections to the connecting strip of the loudspeaker, and also the connection to the bottom screening.
3. Loosen the cable securing the pointer by releasing the screw A, Fig. 16.
4. Loosen the screw B with a special screwdriver (Code No. 09.991.770). Slacken off the screw cap C and also the end of the wire.
5. The moulded scaleholder cap can now, if necessary, be removed from the front of the cabinet.
6. Loosen the screw D, remove the Bowden wire under the securing eyelet of the loudspeaker, if fitted. The scale drive can now be removed.

## ELECTROLYTIC CONDENSERS.



Fig. 8.

When removing a replacement electrolytic condenser a spanner should be used (Code No. 09.991.540), see Fig. 8.

## SECURING THE COILS AND TRIMMERS.

The coils are secured to the chassis by means of small flanges which form a part of the chassis. When the connections to the coil have been unsoldered the coil should be carefully removed from the chassis and a new coil fitted with the aid of a suitable tool. Should, however, it be found that the flanges have broken off the coil can be securely fixed with the aid of a clamping plate. This special type of clamp may be obtained from the Service Department. The clamping plate is fitted into the opening on the chassis and the flange can then be readjusted so that the coil box is firmly fitted.

## DRIVING MECHANISM.

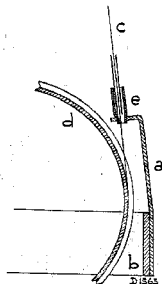

Fig. 9.

The small brackets (a) Fig. 9 which are rivetted to the large brackets (b) and into which the wire (c) is fitted, must be positioned in such a manner relative to the drum (d) so that the centre line of the aperture of the part (c) is at a tangent to the bottom of the groove in the drum.

Furthermore the centre of the part (c) must lie exactly opposite the deepest part of the groove of the drum. If this is not done the wire will run against one of the side edges and is likely to slip off the drum. The part (c) must be soldered to the bracket (a) and care must be taken that these parts have no sharp edges, and also that solder does not run into them.

The driving cord is supplied per metre, and must, before being used, be stretched for one minute with a tension of approximately four pounds.

It is necessary to secure the cord in the teeth of the lever that is situated close to the pivot point. The length of the cord must, in every case, be such that the tension spring is completely closed. If the cord is found to be too long it may be shortened by tying a knot.

### BOWDEN WIRES.

These wires are supplied per metre. The inner wire will be found to be of two types. The thicker type A is employed for operating the variable selectivity coil, while the thinner type B is used for the scale drive.

A slight kink in any of the bowden wires may give rise to very poor adjustment in the running parts, and consequently backlash will be experienced. It will, therefore, be necessary to handle this part of the receiver with care.

### SCALE DRIVE.

Care must be exercised to ensure at the beginning and end of the wave-band range that the variable condenser strikes the stop pin earlier than the indicating pointer. If this is not done there is a possibility for one of the outer ends of the inside wire working loose, and therefore slipping off the drum.

### DESCRIPTION OF WAVELENGTH SWITCH.

The wavelength switch consists of one or more units; a stop plate to determine the number of positions, spindle, springs.

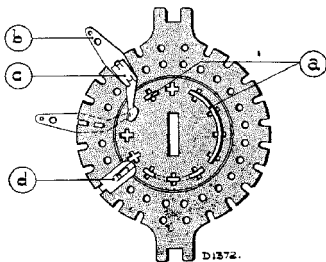

Fig. 10.

The unit (Fig. 10) consists of a stationary ring called the stator, a rotor, contact springs (b) which are secured to the stator with staples (c); one or more springs (d) which keeps the rotor in alignment with the stator and also various types of contact members and connections (a).

The stator is provided with 24 apertures distributed over a circle. On one side of the stator 12 contact springs may be fastened; between the springs one aperture is always left open so that the contact springs on the other side can be secured. Consequently 12 contact springs can be secured on either side of the stator.

### EXPLANATORY NOTES OF THEORETICAL DIAGRAM.

In order that the diagram of the wavechange switch can be understood, the following comments are added:—

The contact springs on the side of the stator that are fitted towards the stop plate are indicated as small circles in the outermost circle.

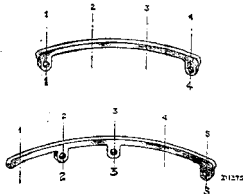

Fig. 11.

When a contact spring is not fitted a dot is shown. Therefore a total of 12 positions can be drawn in the outermost circle. In the innermost circle there are also 12 positions which indicate the contact springs on the other side of the stator.

Connections on the side of the rotor which turns towards the stop plate are shown as full lines in close proximity to the outermost circle, while those on the other side of the rotor are shown as a dotted line close to the innermost circle. Contact pieces are indicated as short lines between the inner and outer circles.

The outer contacts cover one or more apertures, and form on one side a part of the circuit.

The contacts are provided with lips that fit into the aperture of the rotor and by means of which the contacts are securely fixed. This is done by pressing them together with a pair of very smooth pliers, and the lip may also, on the other side, again act for contact purposes.

It is therefore essential to take precautions that the lip is truly flat.

### DESCRIPTION OF CONNECTING PIECES IN THE LIST OF SPARE PARTS.

The connections (Fig. 12) may be made in several types, and therefore a special method has been adopted so as to make quite sure which type of connection is intended.

The first number specifies the number of apertures that are covered, while the other numbers indicate into which aperture the lip is fitted. For example, 4.1.4 denotes that four apertures are covered, and that, starting from the left, the apertures 1 and 4 are made for fixing and also contact purposes on the other side. 5.2.3.5 denotes that five apertures are covered, and that the apertures 2.3.5 are used for securing and also for contacts on the opposite side. The connecting pieces are shown in this manner in the list of spare parts so that it will be possible to immediately know the code number of the part.

**LOUDSPEAKER.**

The code number of the loudspeaker is 28.999.660, Type No. 2369.

When repairs are made to a loudspeaker it is important that they are executed on a bench free from dust and also that good tools are used. On no account may the front and rear plates be removed as the magnetism is likely to be affected.

It is important that the cover of the loudspeaker is replaced immediately the repair is finished.

The cone is centred by means of four small feelers, Code No. 09.990.840 and these are inserted in the air gap through the perforations of the spider.

When it is desired to renew a cone carrier or to

re-centre the pole piece, a special template is necessary (see Fig. 12). Before repairing a loudspeaker make sure that there is a fault by trying another loudspeaker, and possibly another transformer so as to ascertain that the fault does not originate in the receiver itself.

Where rattling or resonance is experienced, it is important to make sure that it is not due to some loose part in the cabinet. Alternatively too tight or too loose connections to the speech coil or dirt in the air gap will cause rattling.

**NOTE.**—When the cone is moved upwards and downwards as shown in Fig. 13 no sound should be audible when held close to the ear.



Fig. 12.



Fig. 13.

## LIST OF SPARE PARTS, TOOLS, GAUGES, TEST GEAR, ETC.

When ordering any of these spare parts please state:—

1. Code number of spare part.
2. Type and serial number of receiver.
3. Description of spare parts.

Fig.	Item.	Description of Parts.	Code No.
17	1	Cabinet ... ..	28.243.820
		Metallised paper ... ..	06.595.980
		Loudspeaker silk ... ..	06.600.730
17	2	Escutcheon, colour 005 ... ..	23.684.095
17	2a	Lower section, rising scale, colour 005 ... ..	23.684.064
		Locking ring ... ..	28.450.910
17	3	Trade mark disc ... ..	28.936.331
17	4	Station scale ... ..	28.705.160
17	5	Diffusion screen ... ..	28.338.563
17	6	Pointer ... ..	28.896.103
17	7	Small knob, colour 005 ... ..	23.610.250
17	8	Large knob, colour 005 ... ..	23.610.261
16	9	Flat spring for fixing backplate (top) ... ..	28.750.040
16	10	Flat spring for fixing backplate ... ..	25.673.860
16	11	Backplate ... ..	28.400.210
16	12	Cap for voltage tapping plate ... ..	28.855.291
16	13	Plate with pins ... ..	28.871.762
16	14	Safety contact, colour 111 ... ..	25.742.000
16	15	Bottom bush (foot) ... ..	28.890.300
16	16	Plug pin plate ... ..	28.870.750
16	18	Plug socket plate ... ..	28.888.361
16	19	Plug socket plate with switch ... ..	28.871.820
		Knob for mains-aerial switch ... ..	23.610.231
		Spindle for mains-aerial switch ... ..	28.616.652
		Switch ... ..	08.524.690
16	20	Valve (grid) cap ... ..	28.855.310
16	21	Inner control cable A ... ..	33.635.590
16	21	Inner control cable B ... ..	33.006.070 or 33.635.570
16	22	Outer control cable ... ..	33.635.050
16	23	Nipple ... ..	28.927.383
16	23a	Eyelet ... ..	08.550.260
15	24	Spindle, for volume control ... ..	28.618.622
15	25	Spindle, for tuning condenser ... ..	28.002.530
15	25a	Locking ring ... ..	07.891.011
15	26	Mains switch ... ..	08.529.570
15	27	Driving cord ... ..	06.606.290
15	27a	Cord clip ... ..	28.078.611
15	28	Tension spring for Bowden cable ... ..	28.730.462
15	29	Tension spring for driving cord ... ..	28.730.600
15	30	Lever ... ..	28.914.333
15	31	Valve holder, 7-pin ... ..	28.225.420
15	32	Valve holder, 5-pin ... ..	28.225.900
15	33	Nut for electrolytic condenser ... ..	07.093.020
15	34	Rotor ... ..	28.477.210
15	35	Stator ... ..	28.934.580
		Rotor contact 1.1 ... ..	28.904.161
		Rotor contact 3.2 ... ..	28.904.211
		Rotor contact 4.1.4 ... ..	28.904.182
		Rotor contact 4.2.4 ... ..	28.904.290
		Stator contact ... ..	28.750.970
		Clip for stator contact ... ..	28.077.391

## LIST OF SPARE PARTS AND TOOLS—continued.

Fig.	Item.	Description of Parts.	Code No.
		Guide bracket ... ..	28.077.380
		Spring for wavelength switch stop ... ..	28.751.800
		Ball for wavelength switch ... ..	89.205.040
		Clip for fixing coils and trimmers ... ..	28.080.870
		Clamping plate for loudspeaker ... ..	25.012.210
		Single pole plug ... ..	08.281.720
		Mains plug ... ..	08.280.350
		Mains lead (flex) ... ..	33.981.080
		Loudspeaker chassis ... ..	28.253.260
		Service clamping ring for loudspeaker ... ..	28.445.821
		Paper washer ... ..	28.445.390
<b>TEST APPARATUS, TOOLS, GAUGES, ETC.</b>			
1		Service oscillator ... ..	09.991.260
		Right-angle screwdriver ... ..	09.990.360
6		Universal test-board, type 4256 ... ..	09.991.030
7		Universal chassis holder ... ..	09.991.380
8		Box spanner for electrolytic condenser ... ..	09.991.540
		Lever for fixing coils ... ..	09.991.560
		Test prod ... ..	09.991.622
3		15° jig ... ..	09.991.741
12		Centring jig for speaker ... ..	09.991.022
		Pertinax gauges for loudspeaker ... ..	09.990.840
4		Insulated screwdriver for trimming ... ..	09.991.501
		Insulated trimming spanner ... ..	09.991.810

## TABLE OF VOLTAGES AND CURRENTS.

	L1 (FC4)	L2 (VP4B)	L3 (UD14)	L4 (Pen.M)	
V <sub>a</sub>	270	270	95	245	Volts
V <sub>g'</sub>	—	160	—	270	Volts
V <sub>g'2-3-5</sub>	75	—	—	—	Volts
I <sub>a</sub>	2.5	0.5	0.8	38.0	mA
I <sub>g'</sub>	g3=5=4.7 g2=1.8	2.2	—	4.8	mA

Dial Lamp, Type 8042.

Rectifier Type 1821.

Voltage across C2 = 280 v.

The voltages are measured with voltmeters having a resistance of 2,000 Ohms per volt. Moving coil voltmeters give readings which depend upon the resistance in circuit and the current consumption of the meter itself. The values given above are the mean of several measurements, therefore some readings obtained may differ appreciably, particularly as variations may arise due to the tolerance of the components as well as the valves. Before finally deciding that a valve is defective, it is recommended that a replacement test with the same type of valve is made.



## RESISTANCES.

Designation.	Value.	Code No.
R1	2 × 1 Watt 40000/2 Ohm	28.771.060
R4	0.25 Watt 250 Ohm	28.773.640
R5	0.25 Watt 250 Ohm	28.773.640
R9	0.25 Watt 3200 Ohm	28.773.750
R10	0.25 Watt 0.1 M. Ohm	28.773.900
R11	0.25 Watt 50000 Ohm	28.773.870
R12	0.5 Watt 1 M. Ohm	28.770.550
R13	0.25 Watt 0.5 M. Ohm	28.773.970
R14	0.25 Watt 0.25 M. Ohm	28.773.940
R15	0.25 Watt 0.5 M. Ohm	28.811.261
R16	0.25 Watt 40000 Ohm	28.773.860
R17	0.5 Watt 1 M. Ohm	28.770.550
R18	0.25 Watt 3200 Ohm	28.773.750
R19	0.5 Watt 1.6 M. Ohm	28.770.570
R20	0.25 Watt 0.5 M. Ohm	28.773.970
R21	0.25 Watt 0.2 M. Ohm	28.773.930
R22	0.25 Watt 50000 Ohm	28.811.021
R23	0.5 Watt 100 Ohm	28.770.150
R25	2 × 1 Watt 16000 Ohm	28.771.020
R26	0.25 Watt 32 Ohm	28.773.550
R27	0.5 Watt 160 Ohm	28.770.170
R31	0.25 Watt 10000 Ohm	28.773.800
R32	0.25 Watt 50 Ohm	28.773.570

## CONDENSERS.

C1	32 $\mu$ F	28.180.130
C2	32 $\mu$ F	28.180.130
C4	50 $\mu$ F	28.182.000
C5	0.1 $\mu$ F	28.199.090
C8	50000 $\mu\mu$ F	28.201.150
C9	0.1 $\mu$ F	28.201.180
C10	11—490 $\mu\mu$ F	28.211.421
C11	11—490 $\mu\mu$ F	
C12	11—490 $\mu\mu$ F	
C13	12—170 $\mu\mu$ F	see Coils
C14	2.5—30 $\mu\mu$ F	see Coils
C15	2.5—30 $\mu\mu$ F	see Coils
C17	2.5—30 $\mu\mu$ F	see Coils
C18	2.5—30 $\mu\mu$ F	see Coils
C22	12—170 $\mu\mu$ F	28.211.310
C23	12—170 $\mu\mu$ F	see Coils
C24	12—170 $\mu\mu$ F	28.211.310
C25	12—170 $\mu\mu$ F	see Coils
C26	500 $\mu\mu$ F	28.192.500
C27	0.1 $\mu$ F	28.199.090
C28	10 $\mu\mu$ F	28.206.340
C29	16000 $\mu\mu$ F	28.201.100
C30	25000 $\mu\mu$ F	28.201.120
C31	16 $\mu\mu$ F	28.206.360
C32	700 $\mu\mu$ F	28.192.260
C33	1490 $\mu\mu$ F	28.192.270
C34	100 $\mu\mu$ F	28.206.270
C35	0.1 $\mu$ F	28.201.180
C36	6.4 $\mu\mu$ F	28.206.320
C37	10000 $\mu\mu$ F	28.201.080
C38	100 $\mu\mu$ F	28.206.270
C39	250 $\mu\mu$ F	28.190.170
C40	20000 $\mu\mu$ F	28.199.020
C41	1000 $\mu\mu$ F	28.199.650
C42	50000 $\mu\mu$ F	28.199.820
C44	0.1 $\mu$ F	28.199.090
C45	2 $\mu\mu$ F	28.205.880
C46	2.5—30 $\mu\mu$ F	28.211.830
C47	20 $\mu\mu$ F	28.206.370
C49	800 $\mu\mu$ F	28.190.220
C50	6.4 $\mu\mu$ F	28.206.320

S: 6, 7, 8, 1, 2, 3, 4, 9, 10, 11, 12, 13, 5, 14, 15, 16, 17, 18, 19, 20, 21, 22, 23, 24, 25, 26, 27, 28  
 C: 1, 2, 6, 46, 47, 14, 28, 10, 29, 30, 31, 1, 15, 11, 2, 45, 8, 34, 12, 17, 18, 32, 33, 5, 44, 50, 22, 23, 35, 9, 24, 12, 5, 14, 20, 15, 19, 18, 9, 13, 21, 17, 16, 27, 26, 23, 22, 22, 23, 24, 25, 26, 27, 28

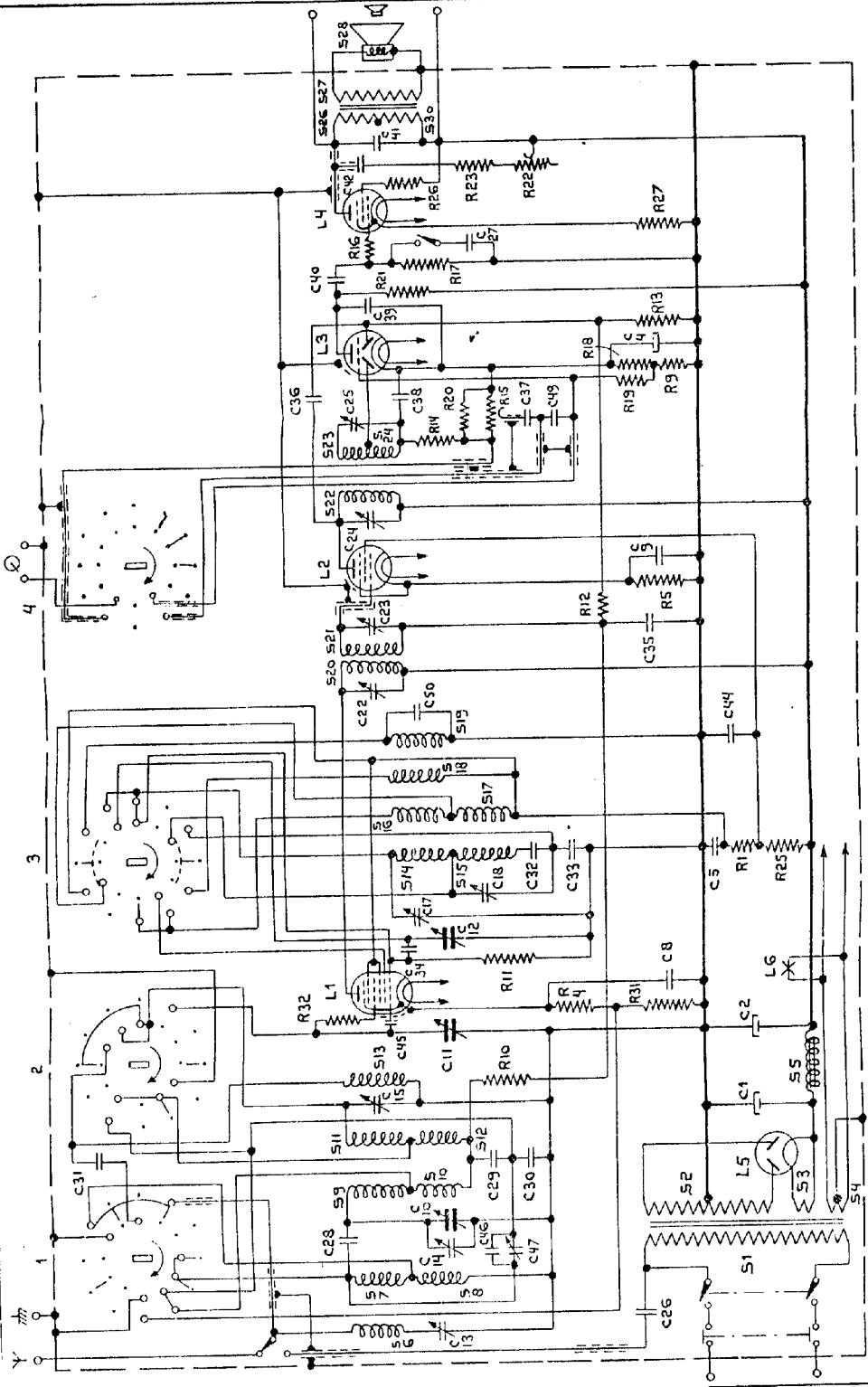



# D.C. RESISTANCES OF COILS.

Designation.	Resistance in Ohms.	Code No.	Designation.	Resistance in Ohms.	Code No.
S5	375—395	28.546.081	S18	32	28.587.090
S6	135	28.570.481	S19	0.4	
S7 } +C14	30		S20	140	28.570.700
S8 } +C14	100	28.570.541	S21	140	
S9 } +C14	5		S22	140	
S10 } +C15	50		S23	35	28.570.720
S11 } +C15	5	28.570.491	S24	105	
S12 } +C15	50		S25	355	
S13	0.3	28.587.080	S30	120	28.530.490
S14	12		S27	1.15	
S15 } +C17,	36	28.570.501	S28	4.0	28.220.200
S16 } C18	4.5				
S17	10.0				

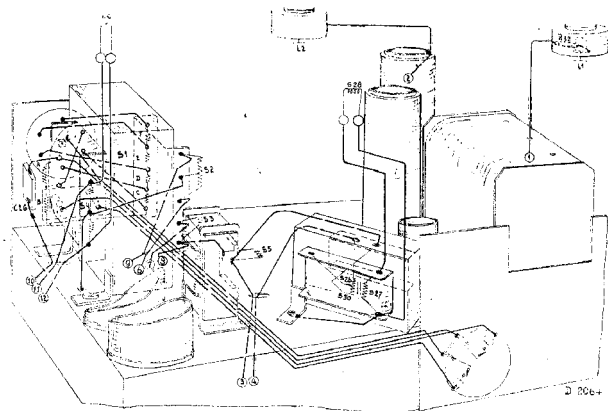

Fig. 14.

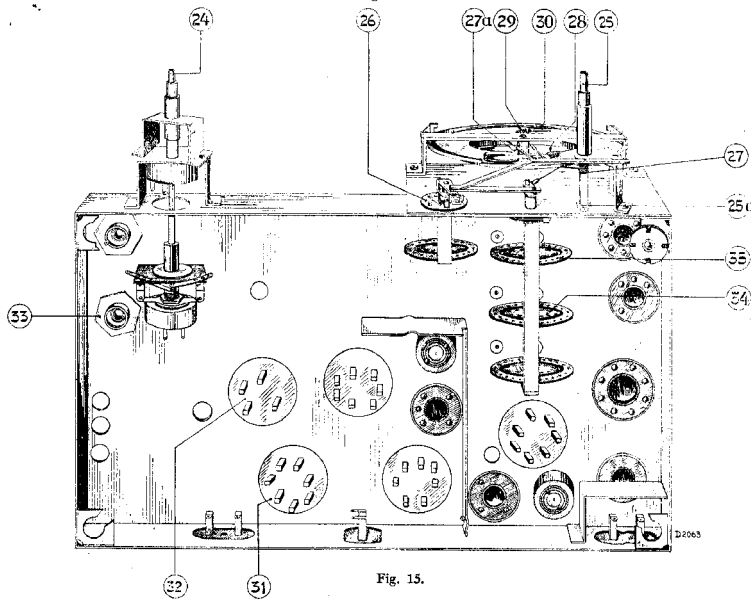

Fig. 15.

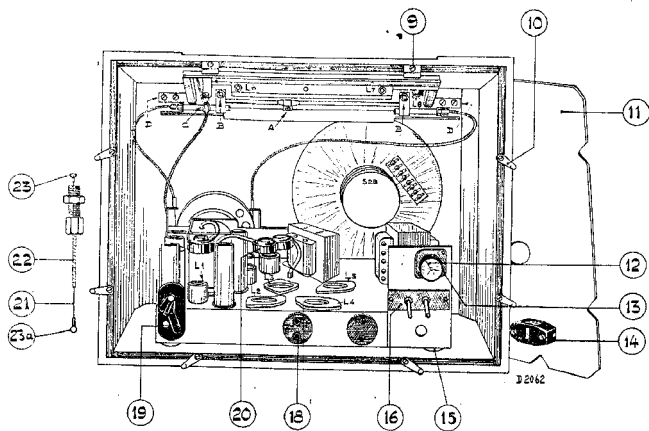

Fig. 16.

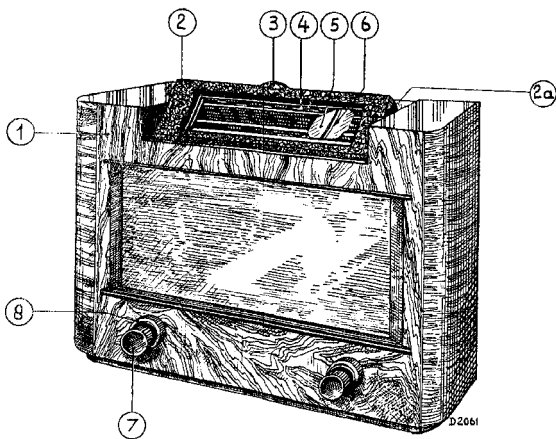

Fig. 17.